

Mini & Service Isolator



Convenient for transport of cages and other supplies.

Flexibility:

Irrespective of the nature of your research, our dedication to tailored and individualized designs guarantees the seamless functionality of your equipment to perfectly align with your needs.

Dimensions and Specifics:

Thanks to our dedication to bespoke design, the dimensions of all our Isolators are able to be custom to your requirements, including, optional extra such as Hydraulic controlled ergonomics.

As Standard, our Mini Isolators are the following dimensions:

Overall: 66cm(L) x 66cm(W) x 155cm(H) (187cm Double)

Canopy: 61 cm(L) x 61 cm(W) x 63cm(H)

Economic and Practical:

Our simple design allows for the best possible use of space within the Isolator while optional hydraulic lift systems provides optimal comfort and reduced strain for users during prolonged use.



✉ sales@nkpisotec.com
🌐 www.nkpisotec.com

Type 1S/D Isolator (M12/24)



**Bio-containment Isolator
capable of holding 12 NKP
housing per canopy.**

Flexibility:

Irrespective of the nature of your research, our dedication to tailored and individualized designs guarantees the seamless functionality of your equipment to perfectly align with your needs.

Dimensions and Specifics:

Thanks to our dedication to bespoke design, the dimensions of all our Isolators are able to be custom to your requirements, including, optional extra such as Hydraulic controlled ergonomics.

As Standard, our Mini Isolators are the following dimensions:

Overall: 120cm(L) x 97cm(W) x 180cm(H)

Canopy: 90cm(L) x 90cm(W) x 75cm(H)

Economic and Practical:

Our simple design allows for the best possible use of space within the Isolator while optional hydraulic lift systems provides optimal comfort and reduced strain for users during prolonged use.

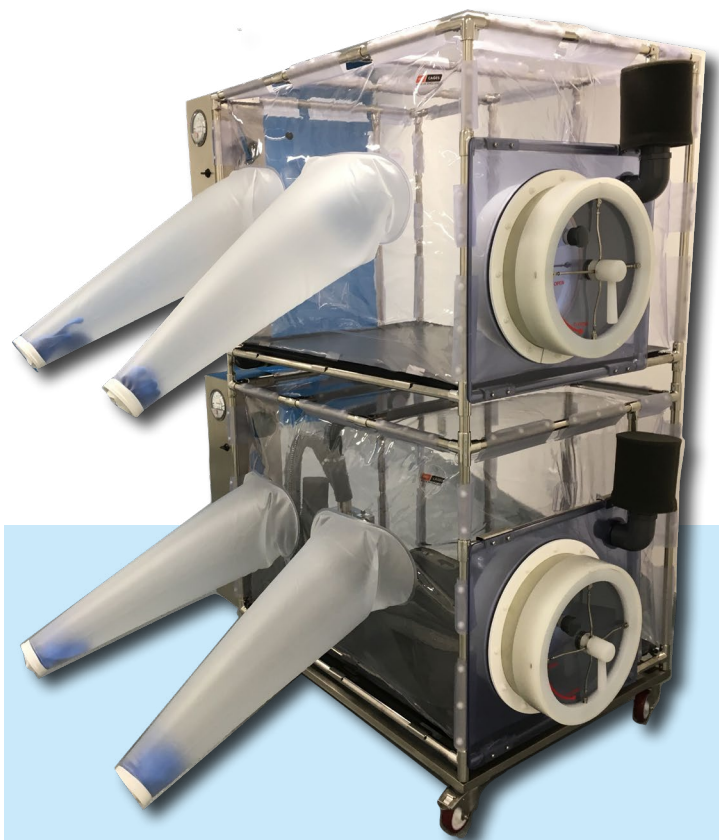

✉ sales@nkpisotec.com
🌐 www.nkpisotec.com

Type 2S/D Isolator (M20/40)



Bio-containment Isolator capable of holding 20 NKP housing per canopy.

Flexibility:

Irrespective of the nature of your research, our dedication to tailored and individualized designs guarantees the seamless functionality of your equipment to perfectly align with your needs.

Dimensions and Specifics:

Thanks to our dedication to bespoke design, the dimensions of all our Isolators are able to be custom to your requirements, including, optional extra such as Hydraulic controlled ergonomics.

As Standard, our Mini Isolators are the following dimensions:

Overall: 166cm(L) x 95cm(W) x 185cm(H)

Canopy: 114cm(L) x 90cm(W) x 82cm(H)

Economic and Practical:

Our simple design allows for the best possible use of space within the Isolator while optional hydraulic lift systems provides optimal comfort and reduced strain for users during prolonged use.



✉ sales@nkpisotec.com
🌐 www.nkpisotec.com

Type 3S/D Isolator (M50/100)



**Bio-containment Isolator
capable of holding 50 NKP
housing per canopy.**

Flexibility:

Irrespective of the nature of your research, our dedication to tailored and individualized designs guarantees the seamless functionality of your equipment to perfectly align with your needs.

Dimensions and Specifics:

Thanks to our dedication to bespoke design, the dimensions of all our Isolators are able to be custom to your requirements, including, optional extra such as Hydraulic controlled ergonomics.

As Standard, our Mini Isolators are the following dimensions:

Overall: 238cm(L) x 97cm(W) x 243cm(H)

Canopy: 190cm(L) x 90cm(W) x 97cm(H)

Eronomic and Practical:

Our simple design allows for the best possible use of space within the Isolator while optional hydraulic lift systems provides optimal comfort and reduced strain for users during prolonged use.

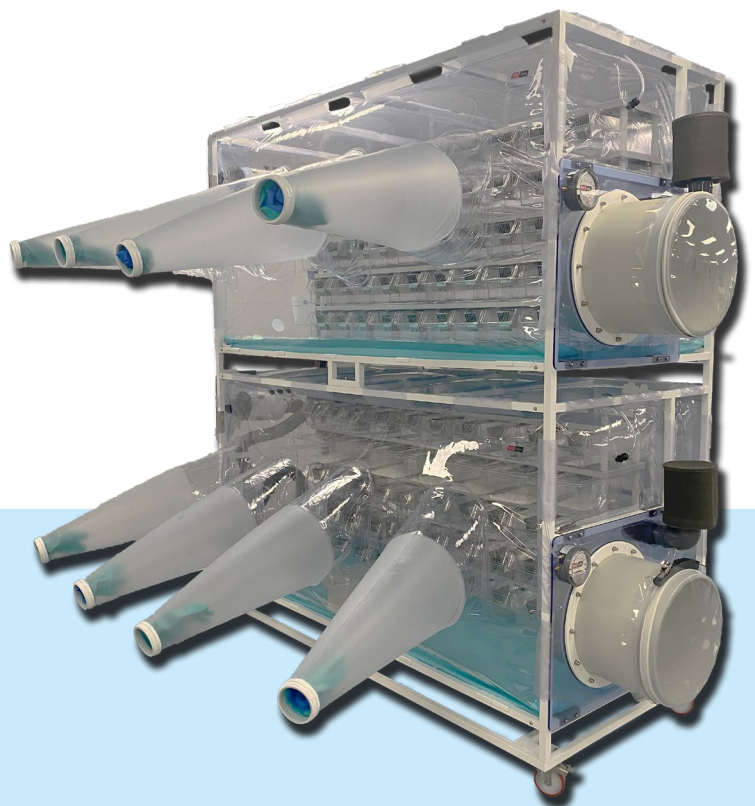

✉ sales@nkpisotec.com
🌐 www.nkpisotec.com

Type 4 Isolator



**Bio-containment Isolator
capable of holding 20 NKP
housing per canopy.**

Flexibility:

Irrespective of the nature of your research, our dedication to tailored and individualized designs guarantees the seamless functionality of your equipment to perfectly align with your needs.

Dimensions and Specifics:

Thanks to our dedication to bespoke design, the dimensions of all our Isolators are able to be custom to your requirements, including, optional extra such as Hydraulic controlled ergonomics.

As Standard, our Mini Isolators are the following dimensions:

Overall: 238cm(L) x 97cm(W) x 243cm(H)

Canopy: 190cm(L) x 90cm(W) x 97cm(H)

Eronomic and Practical:

Our simple design allows for the best possible use of space within the Isolator while optional hydraulic lift systems provides optimal comfort and reduced strain for users during prolonged use.



✉ sales@nkpisotec.com
🌐 www.nkpisotec.com

Surgical Isolator



Bio-containment Isolator which allows best access and control to perform surgical or experimental procedures inside an isolator.

Flexibility:

Irrespective of the nature of your research, our dedication to tailored and individualized designs guarantees the seamless functionality of your equipment to perfectly align with your needs.

Dimensions and Specifics:

Thanks to our dedication to bespoke design, the dimensions of all our Isolators are able to be custom to your requirements, including, optional extra such as Hydraulic controlled ergonomics.

As Standard, our Mini Isolators are the following dimensions:

Overall: 181cm(L) x 69cm(W) x 160cm(H)

Canopy: 127cm(L) x 61cm(W) x 56cm(H)

Economic and Practical:

Our simple design allows for the best possible use of space within the Isolator while optional hydraulic lift systems provides optimal comfort and reduced strain for users during prolonged use.

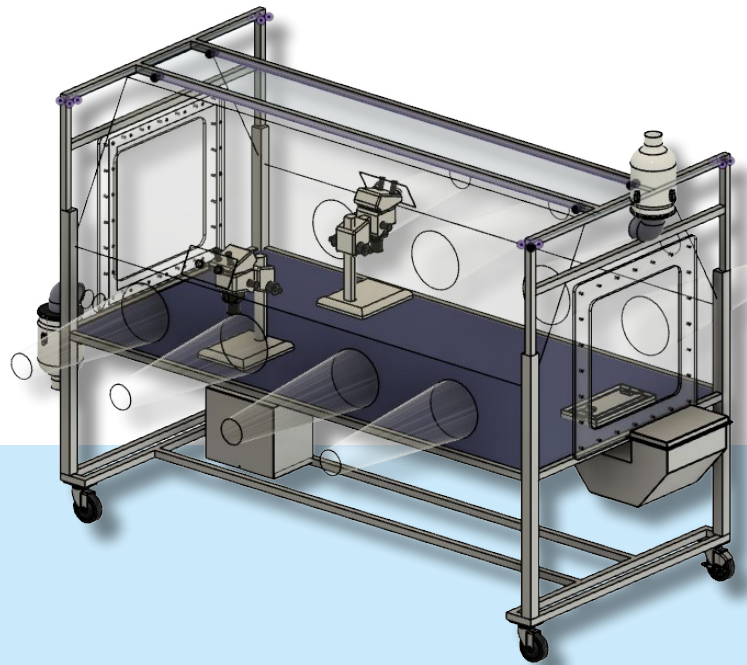

✉ sales@nkpisotec.com
🌐 www.nkpisotec.com

Rigid Isolator



Bio-containment Isolator made using a rigid plastic, available in a range of sizes.

Flexibility:

Irrespective of the nature of your research, our dedication to tailored and individualized designs guarantees the seamless functionality of your equipment to perfectly align with your needs.

Dimensions and Specifics:

Thanks to our dedication to bespoke design, the dimensions of all our Isolators are able to be custom to your requirements, including, optional extra such as Hydraulic controlled ergonomics.

Rigid Isolator are available in our complete range of Isolator and Canopy sizes (Type 1-4).

Contact us for more information regarding our flexibility with Rigid Isolators.

Economic and Practical:

Our simple design allows for the best possible use of space within the Isolator while optional hydraulic lift systems provides optimal comfort and reduced strain for users during prolonged use.

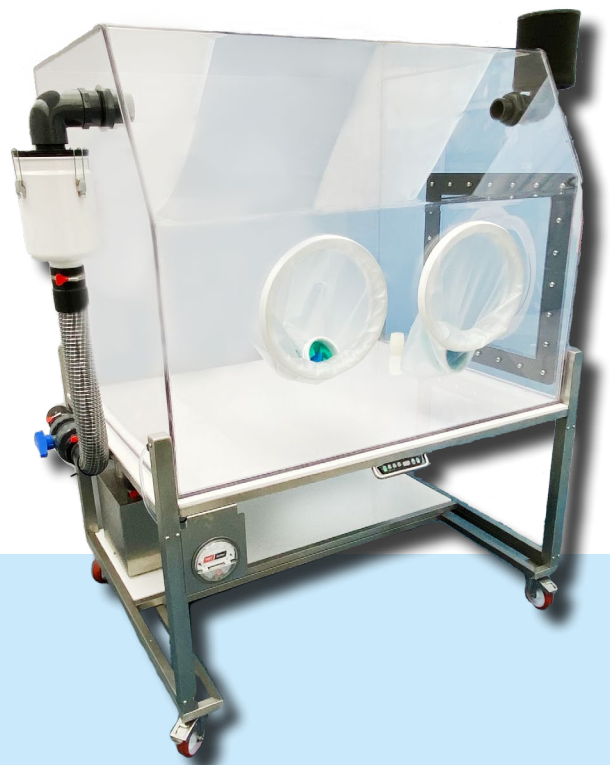

✉ sales@nkpisotec.com
🌐 www.nkpisotec.com

Port Options

Choose from a variety of options depending on your requirements and budget.

Flexible Film Caps Port

Available in 300mm, 400mm or 450mm Port Diameter (compatible to other well know brands)

Flexible film caps are very versatile as they allow many different applications and designs, are interchangeable and have a very good fit. They are attached with grooved silicon bands and stainless steel flat clamps or aluminium cable clamps. Spray nozzles can be either a bung closure or screw caps for extra security.

Quadro-Lock Port

Available in 400mm or 450mm Port Diameter . The quadro lock port can be operated with just one hand for easy use and has all the advantages of a solid door for durability.

Hatch / Single door

Available in a variety of sizes. This hatch or single door is especially useful if larger equipment needs to be brought into the Isolator and would not fit through the normal Import Port. It is possible to fit these doors with electrical plugs and fittings - e.g. USB connections and data connectors for specialised equipment.

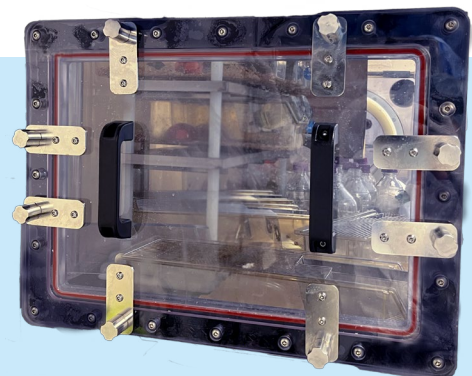

Clamps & Bands

Choose from a variety of styles and materials depending on your requirements.

Bands

Our bands have been designed to fit perfectly to our complete range of Clamps. Using high quality bonded silicon, our bands are autoclavable and can withstand chemical sterilants commonly used in facilities.

Rubber options are still available, for more information on these, contact our team who will be able to provide you with further information.

Metal Clamps

Choose from either a Stainless Steel Flat Clamp or a cable clamp depending on your requirements. All of our clamps are available in sizes ranging from 300mm (12") through to 560mm (22"). All of our clamps are autoclavable.

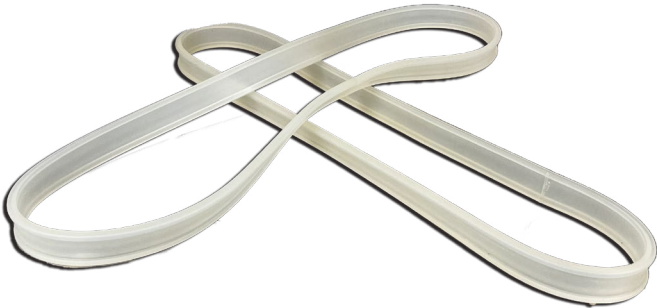

Atomiser & Compressor



Ensure that you are achieving complete coverage when sterilising.

Atomiser

For liquid sterilisation, atomisers ensure a fine spray meaning all surfaces are sufficiently covered with your sterilant without excessive usage.

Our Atomiser is made with non-corrosive Stainless Steel and includes a 500ml detachable bottle for liquid sterilant.

Connection to air is achieved via a quick release fitting. Short and Long nozzles are available. And all of our Atomiser work at pressure between 3 and 5 bar.



Compressors

As standard we offer two types of compressors:

Our Standard Compressor (shown right) operates at 65db. This is mounted on a cart for easy movement. The cart has storage for bottles and atomisers for easy of use.

Alternatively, we offer a silent compressor. This typically works around 45db and can be mounted to movable cart.



✉ sales@nkpisotec.com
🌐 www.nkpisotec.com

Autoclave Drums



Import and export items with ease using our range of Autoclave drums

Supply Cylinders are available in different sizes according to port size or preferred transfer options.

Our standard drum is 18"(45cm) in diameter, 82cm long with large perforations to allow good steam penetration. Additionally, we offer sizes from 12-21".

Available with or without shelves, our shelves are manufactured from aluminium with specially angled runners to avoid accidental damage to gloves and transfer sleeves.

To close the Drums, we offer rolls of Mylar Film or an autoclavable cap made of Viton or Silicon.

We also offer an additional collar attachment (shown right) for those using the caps.

In order to make the set complete we also offer autoclave trolleys compatible to both Isolator and cylinder.

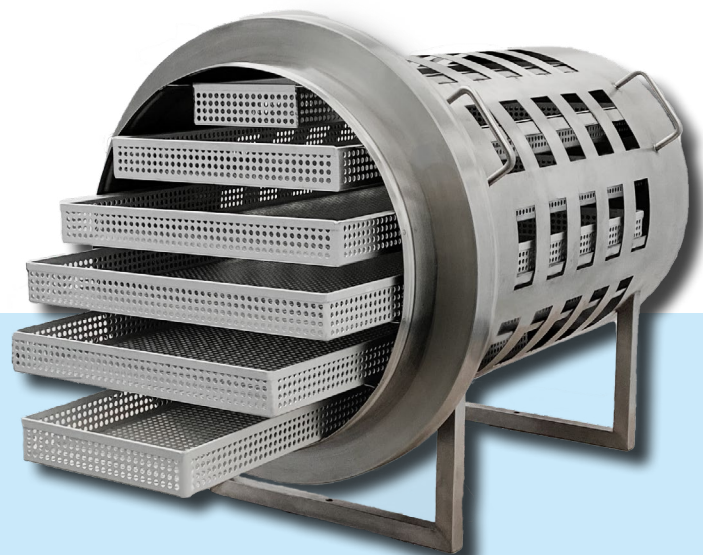

Bespoke Equipment

**Customized for your project,
space, and needs – our
equipment fits flawlessly.**

We understand that each project is unique, and our equipment is meticulously designed to align seamlessly with your specific requirements.

Whether you're working with limited space, intricate layouts, or diverse functional needs, our Bespoke Equipment ensures a perfect fit.

Our expertise lies in crafting equipment that, not only optimizes space, but also enhances efficiency and aesthetics.

With us, you're not just getting equipment – you're getting a bespoke solution that transforms your lab into a harmonious and efficient workspace.

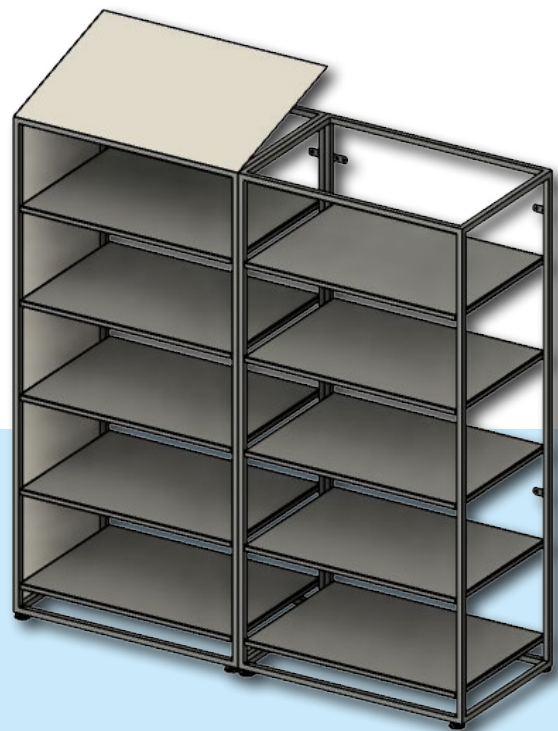

✉ sales@nkpisotec.com
🌐 www.nkpisotec.com

Bespoke Biocontainment

Customized for your project,
space, and needs – our
Biocontainment equipment fits
flawlessly.

We understand that each project is unique, and our equipment is meticulously designed to align seamlessly with your specific requirements.

Whether you're working with limited space, intricate layouts, or diverse functional needs, our Biocontainment Equipment ensures a perfect fit.

Our expertise lies in crafting equipment that, not only optimizes space, but also enhances efficiency and aesthetics.

With us, you're not just getting equipment – you're getting a bespoke solution that transforms your lab into a harmonious and efficient workspace.

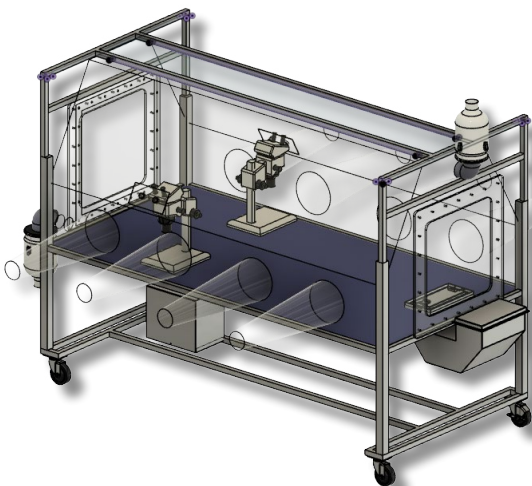
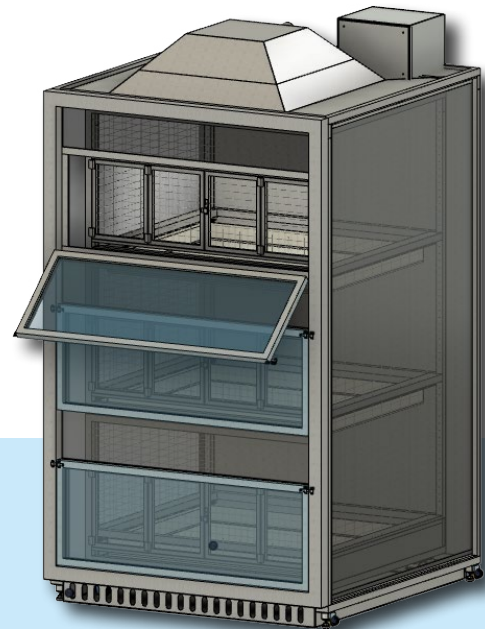
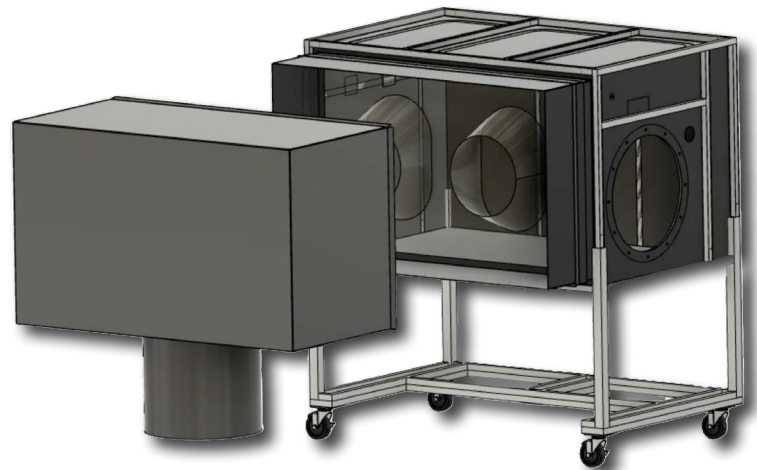

✉ sales@nkpisotec.com
🌐 www.nkpisotec.com

Servicing & Maintenance

Count on Our Expertise: Biocontainment Equipment Servicing and Maintenance



The dependability of your biocontainment equipment is paramount. Trust in Our Expertise for exceptional Biocontainment Equipment Servicing and Maintenance.



Our specialized team comprehends the intricacies of your equipment, ensuring it operates with optimal efficiency.

We meticulously inspect, calibrate, and fine-tune every component, prioritizing the integrity of your research environment.

With a profound understanding of the critical nature of biocontainment, our services go beyond maintenance – they offer you the peace of mind to pursue breakthroughs with confidence.

Elevate your scientific pursuits by entrusting us with the care of your biocontainment equipment.

Get in touch with our team to learn more about our maintenance services, and keep your research on track.

 sales@nkpisotec.com
 www.nkpisotec.com

Gnoto Transport Cage



An innovative solution to Germ-Free Animal Transport.

Introducing our innovative Gnotobiotic Transport Cage, a seamless solution for moving animals between Isolators, procedures, and Facilities.

Designed for simplicity, the clip mechanism ensures effortless use within Isolators.

By integrating DW4 Filter Media into the lid, it ensures that the animals inside the transport housing are able to withstand any changes to their environment.

In addition to this, the complete Transport Cage, comes with a removable sealing sticker so that the cage can be easily sterilised without risking exposure to the animals inside.

Finally, the cage has been built with environmental impact in mind. The entire cage is autoclaveable, and all except the sealing sticker can be reused.

Get in touch with our team to learn more about the Gnoto Transport Cage and accessories.



✉ sales@nkpisotec.com
🌐 www.nkpisotec.com